

TDI **TURBOTWIN™** Model T50-Y Pre-engaged Air Starter

TURBOTWIN™ Model T50-Y ENGINE AIR STARTERS

- The TDI *TURBOTWIN* T50-Y air starter is suitable for starting either gas or diesel models up to 70 liters (4200 CID)... see installation and selection guidelines. This includes MTU 6V396 & 8V396 engines and Cummins QSK 45 & 60 engines.
- The turbine motor used in the model T50-Y is the same rugged design used in the complete line of *TURBOTWIN* starters. Properly installed, the *TURBOTWIN* motor is highly resistant to damage caused by wet or hard contaminated drive air. A strainer may be recommended on the air supply circuits which actuate starter pinion engagement.
- Installation requires only a starter relay valve (recommend TDI *TURBOVALVE*), and operation within each starter model recommended maximum pressure. The T50-Y features modular construction and individual parts are easily serviced. This provides T50-Y users with simple and low cost starter repair and overhaul in the future.
- The T50-Y's efficient twin-turbine motor now delivers more torque using less air than previous starter designs. The T50-Y is offered in both standard pressure (10 nozzle) and low pressure (14 nozzle) versions. In addition, the T50-Y's superior engagement mechanism provides users with true low pressure operation... on air pressures as low as 40 psig.
- The gear train and bearings are factory grease-packed for the life of the starter, therefore it requires no maintenance. There are no rubbing parts, so there is no external lubrication required. Lubricator problems, installation expense, system maintenance, and the messy and hazardous oil film around the starter exhaust can be eliminated.
- *TURBOTWIN* T50-Y starters are constructed from durable, corrosion resistant, and high quality materials. Major components are made from high strength aluminum or steel alloy. As with all *TURBOTWIN* series starters, there are no plastic parts inside.
- The T50-Y can be used over a wide range of drive pressures from 40 psig (2.7 BAR) to 120 psig (8 BAR). The lightweight, 34 lb. (15.4 KG) unit is capable of delivering over 45 HP (33.60 kW) of cranking power at only 120 psig (8 BAR).

**APPLICATION
VERSATILITY**

**CONTAMINATED
SUPPLY AIR**

SIMPLICITY

**LOW AIR
CONSUMPTION**

**NO MAINTENANCE
DESIGN and
ENVIRONMENTALLY
SAFE**

**HEAVY DUTY
CONSTRUCTION**

**BROAD RANGE of
OPERATION**

- The high power of a turbine air motor combined with a planetary gear speed reducer results in a very efficient and reliable unit. A two stage axial flow turbine coupled to a spur gear reduction set powers the *TURBOTWIN* T50-Y.
- Tech Development Inc. introduced the first turbine technology for starting industrial engines in 1979. The *TURBOTWIN* T50-Y starters feature an innovative and more reliable turbine motor than anything on the market today.
- The *TURBOTWIN* T50-Y is the result of TDI's continuing turbine starter design innovations. Based on our successful *TURBOTWIN* T30 Series starters, the *TURBOTWIN* T50-Y starters should exceed customer requirements in every installation.

DESCRIPTION OF OPERATION

DEVELOPMENT HISTORY

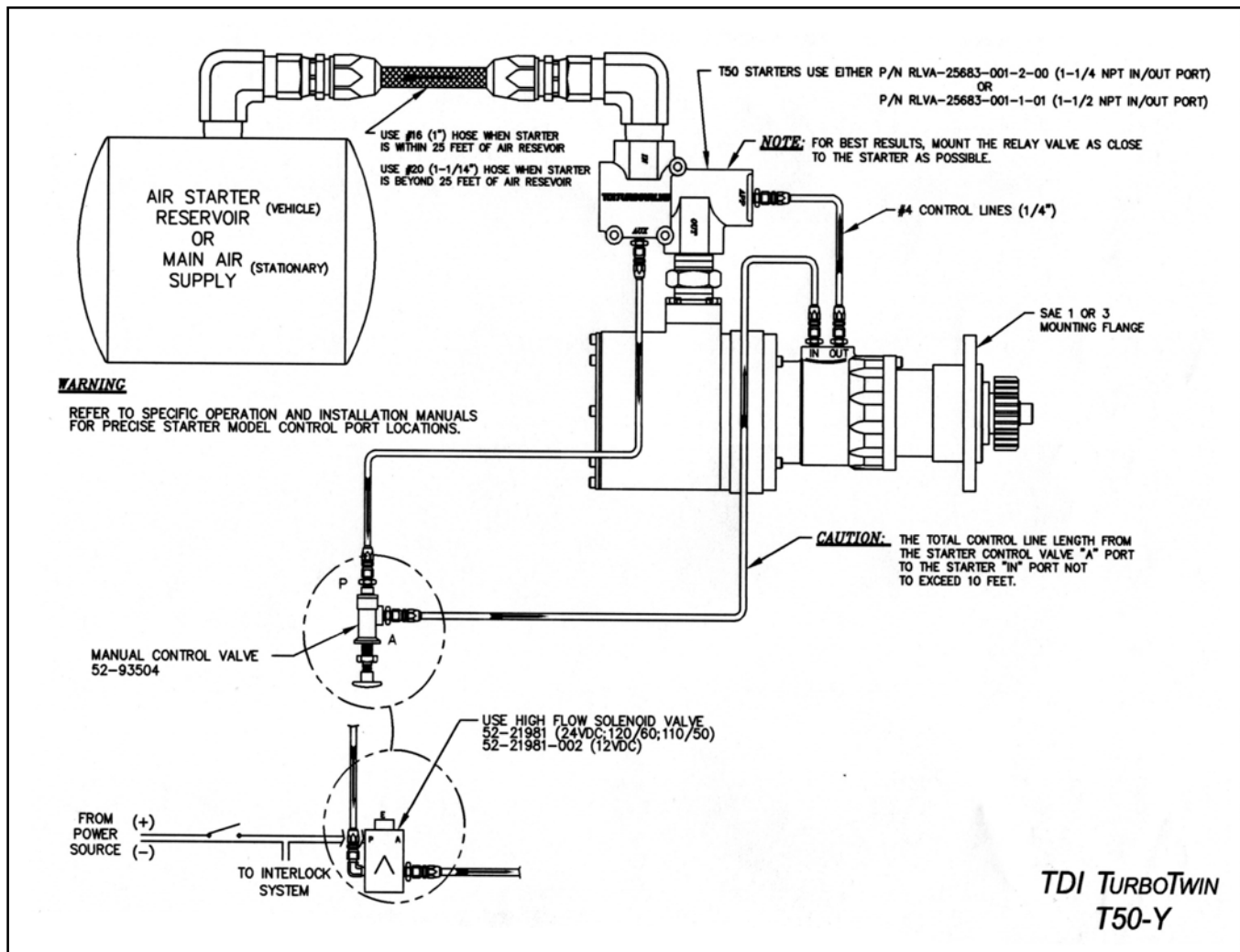

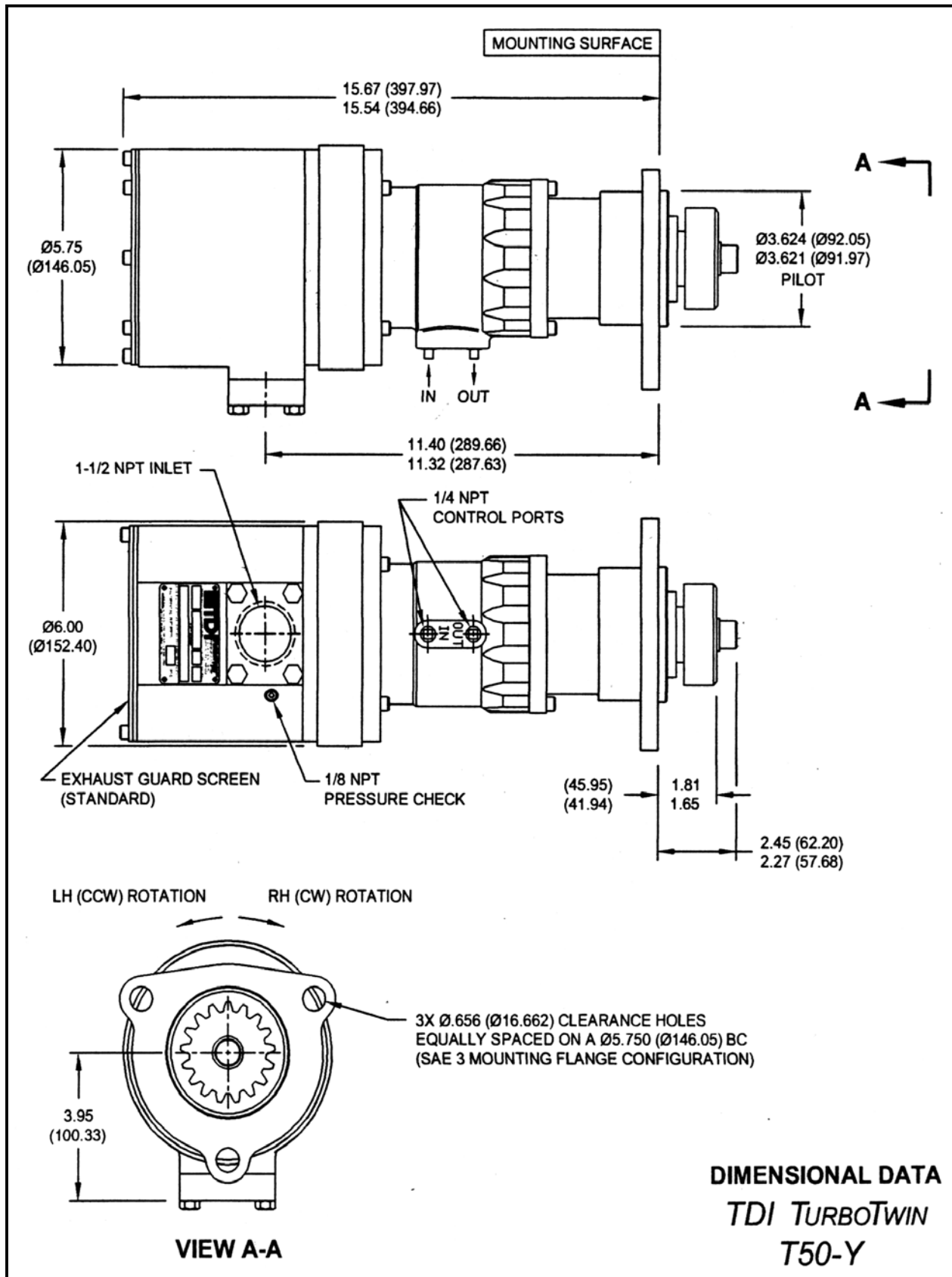

TDI **TURBOTWIN** T50-Y PERFORMANCE CURVES

Model: T50-Y
10 Nozzles
70° F, Compressed Air
11.2:1 Gear Ratio

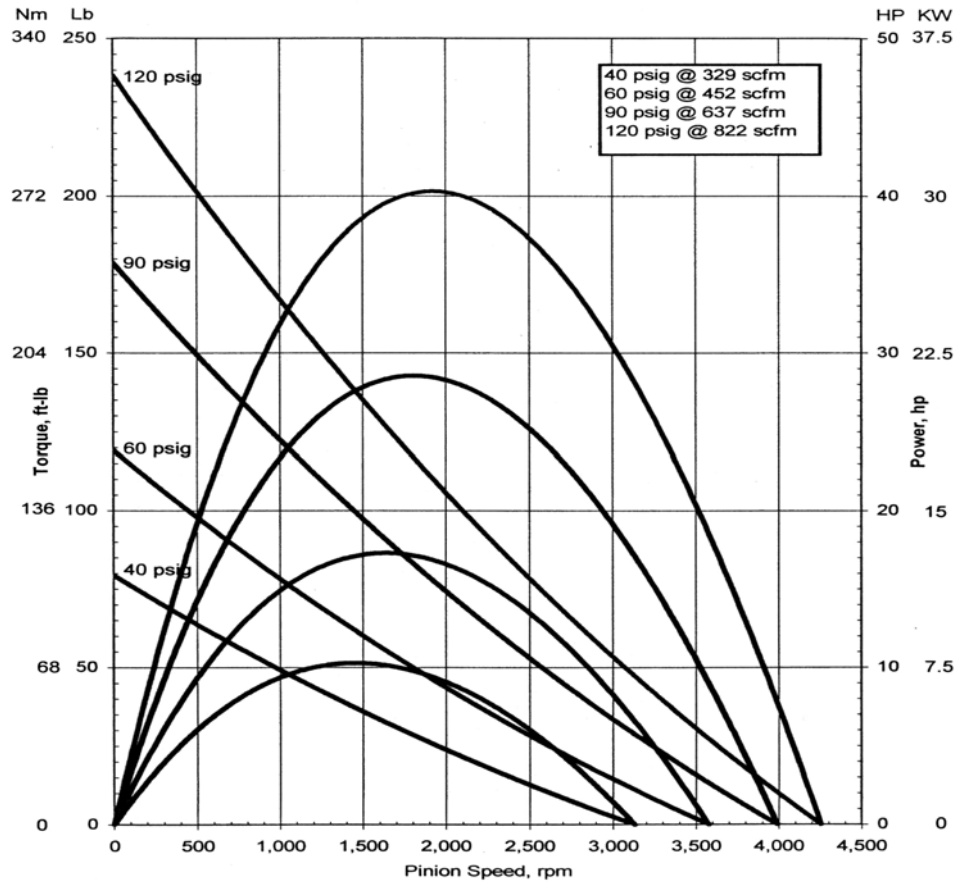

Model: T50-Y
14 Nozzles
70° F, Compressed Air
11.2:1 Gear Ratio

